

# MoistScan<sup>®</sup> MA-600CMA

## In-Chute Microwave Moisture Analyser

### General Description

The MoistScan<sup>®</sup> MA-600CMA is designed specifically for applications where measuring the moisture in a material as it passes through a chute or hopper is required. The MA-600 antenna configuration is specially configured to overcome typical problems associated with material falling under gravity and where presentation of the material to the analysis zone is inconsistent. Each set of antenna are custom-designed depending on the size and dimensions of the hopper or chute.



MINING

AGRICULTURE

CHEMICALS

BUILDING MATERIALS

FOOD

BIOFUELS



### Benefits

- Superior Precision and Accuracy
- Belt Scale not required
- Non Contact
- Non Nucleonic
- Low Whole of Life Costs
- Seamless Plant Integration
- Remote Access Calibration & Servicing

### Features

- Analyses 100% of the material
- Uses MoistScan<sup>®</sup>, the most widely used online microwave analysis technology on the market for measuring moisture in bulk materials.
- Analyser operates independant of mass flow rate
- No contact with the material being analysed
- No radioactive source is required
- As no beltweigher or radioactive sources is required ongoing costs associated with servicing and regulatory compliance is minimal
- Wide range of communication options for transmitting data to Plant PLC
- Cost-effective remote communication access for periodic checking of calibration

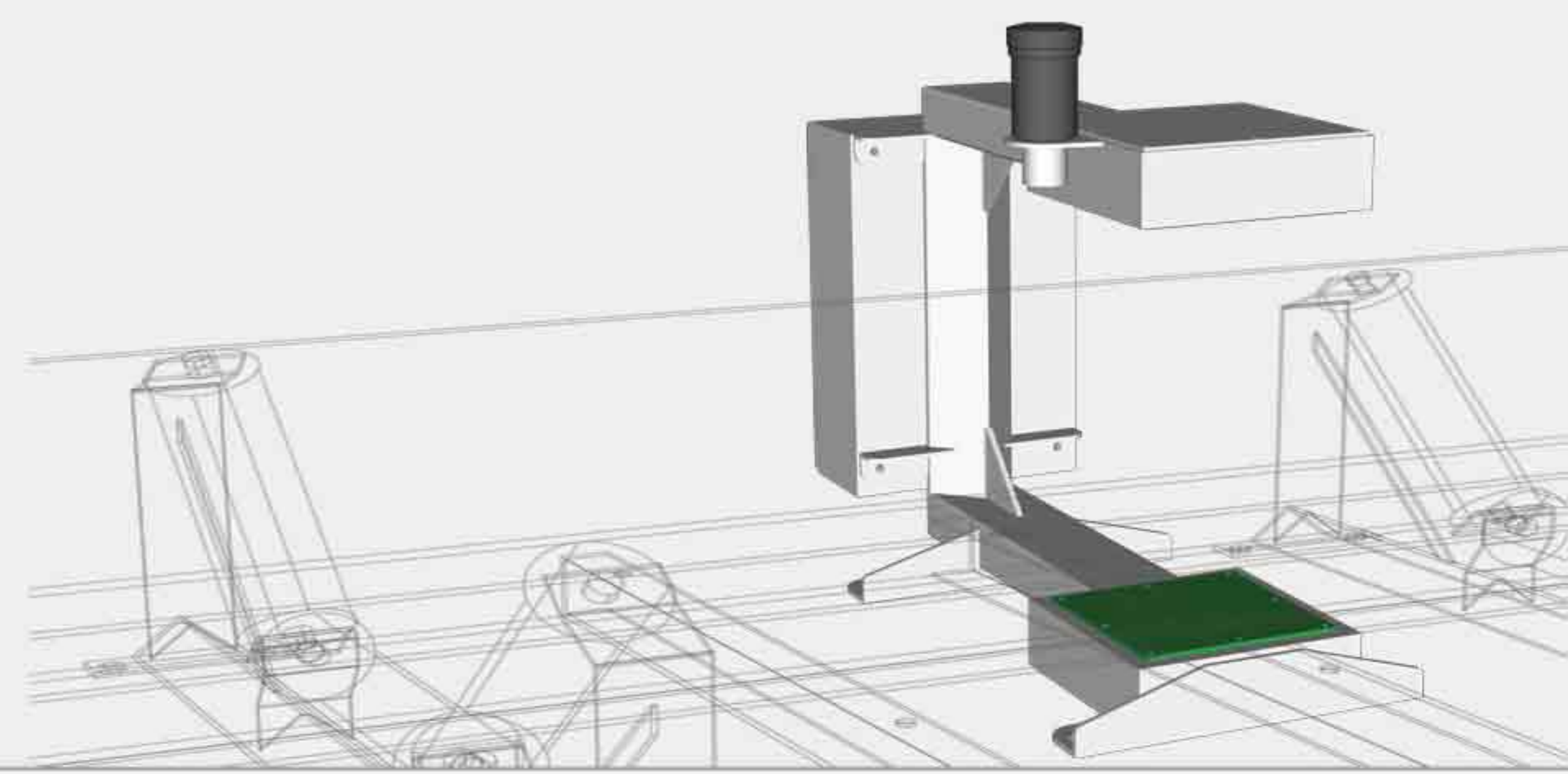

## The MoistScan<sup>®</sup> microwave advantage

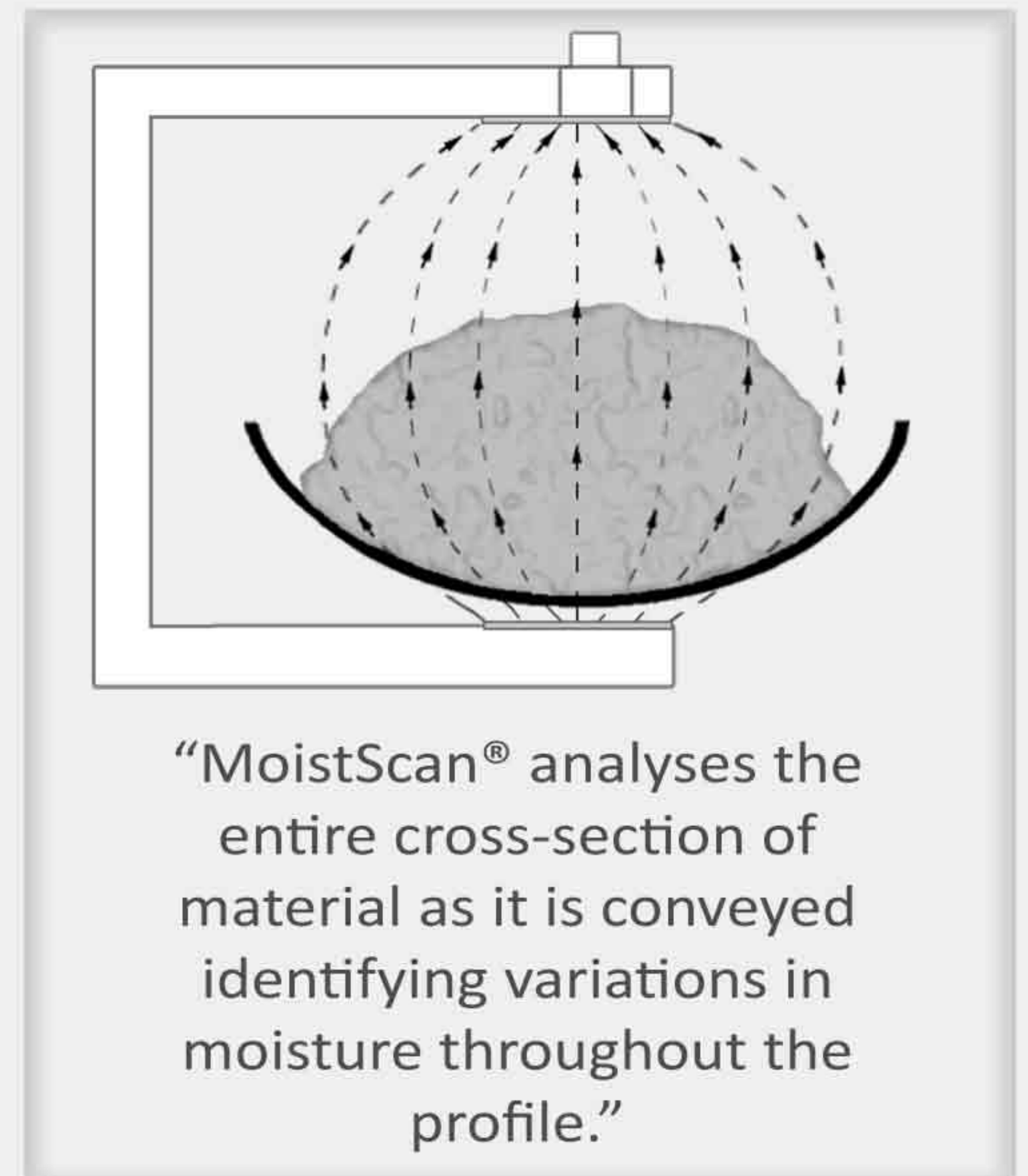
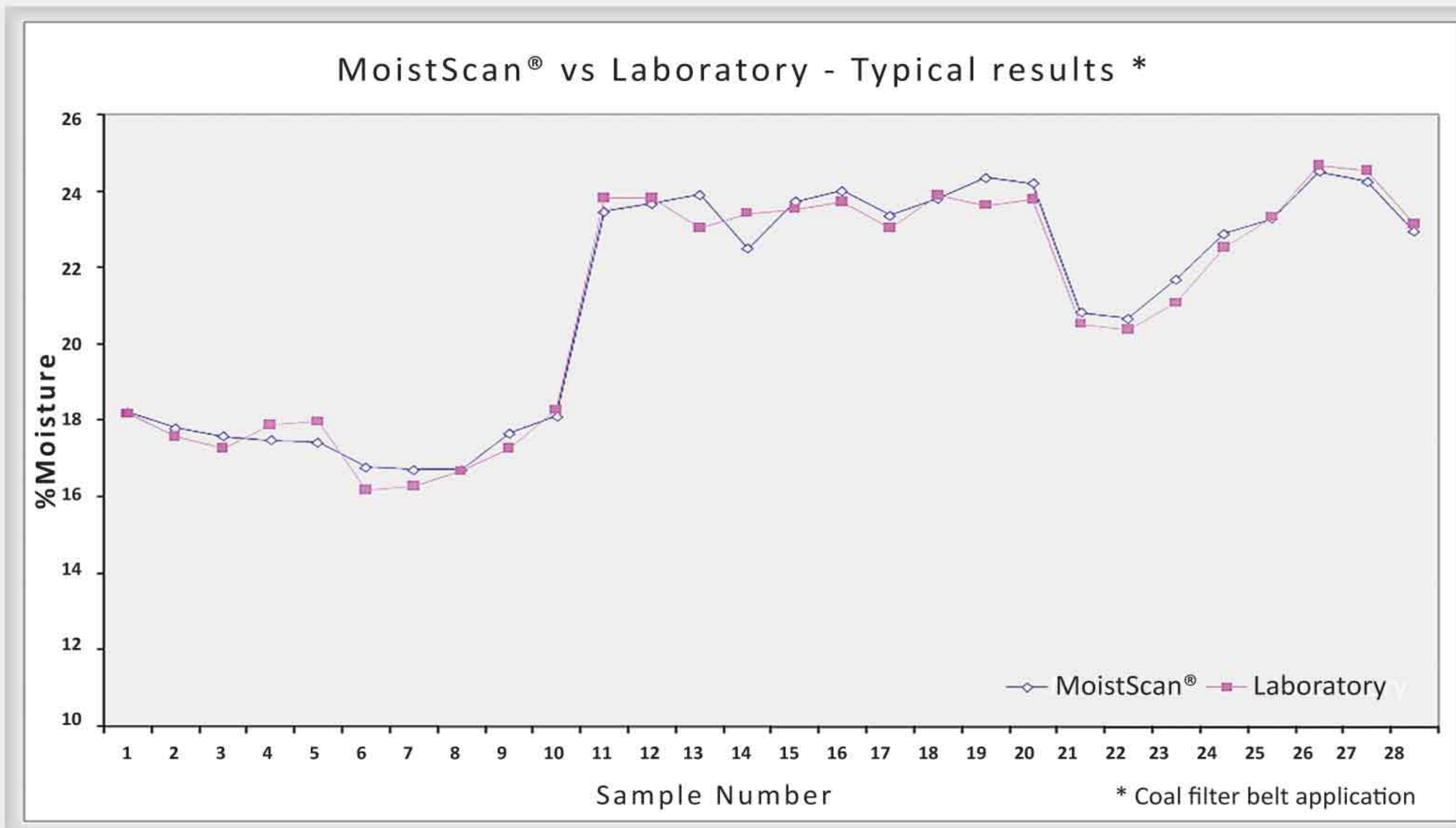

## Specifications

Instrument Precision:	Typically 0.3% at 1SD (subject to application and material composition)
Measurement Range:	0 to 90% moisture
Measurement Freq:	50Hz
Communications:	Ethernet TCP/IP, Modbus (in-built protocol converter enables connection via most popular brand communication protocols)
Operator Interface:	LCD touch panel display on control cabinet (colour & trend display options)
Operating Temp Range:	0 to 50° Celsius (extreme temperature options)
Humidity Range:	0 to 90% relative (non-condensing)
Power:	110/240VAC 60/50Hz, 300 watts maximum dissipation (24V, 48V DC options)
Control Cabinet:	Steel powder coated NEMA 4X/IP66 (stainless steel, food grade CIP, explosion proof options)
Outputs:	Instantaneous moisture and average moisture via 2 x 4-20mA analog outputs (digital output via RS232, RS485, serial/ethernet options)

Your local MoistScan<sup>®</sup> Representative:



**AUSTRALIA - HEAD OFFICE**

Ph: 617 49 555 966 | Fx: 617 49 557 338 | [www.callidan.com](http://www.callidan.com)  
Lot J Mackay Marina Village, Mulherin Drive.  
PO Box 6920 Mackay MC. QLD AUSTRALIA. 4741

**GLOBAL REPRESENTATIVES**

Americas | Europe | Asia | Oceania | Africa | Middle East

